

MSI

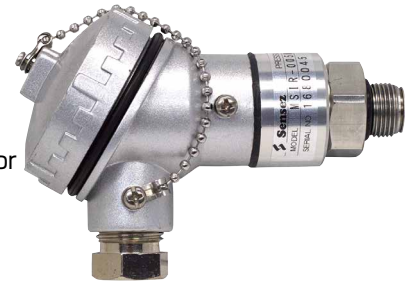

Features 1. Terminal box type 2. For medium and high pressure

- Terminal box type of the "HS series" flat-type medium and high pressure sensor
- Outdoor specification / Waterproof IP67 structure
- Flat-type diaphragm ideal for measuring the pressure of viscous fluid
- Output signal of 4 to 20 mADC from a built-in amplifier circuit

Specifications

Model	MSIR					
	-002MP	-003MP	-005MP	-010MP	-020MP	-035MP
Rated pressure	0 to 2MPa	0 to 3MPa	0 to 5MPa	0 to 10MPa	0 to 20MPa	0 to 35MPa
Pressure type	Shield gauge pressure					
Overpressure	150% of the rated pressure					140%
Wetted part material	Diaphragm : SUS316L		Pressure port : SUS316	O-ring : Fluororubber (standard)		
Sealing liquid	Silicone oil					
Applicable media	Gas and fluid (media not damaging the wetted part material)					
Power supply	12 to 28VDC					
Output	4 to 20mADC					
Load resistance	600 Ω or less (at power of 24 VDC)					
Responsiveness	5msec or less					
Accuracy (linearity)	± 0.5% F.S. or less * 1 (± 0.3% F.S. or less)					
Temperature characteristics	± 0.05% F.S. / °C or less (0 to 60°C)					
Compensated temperature range	0 to 60°C					
Operating temperature range	- 20 to 80°C (no freezing allowed)					
Operating humidity range	35 to 85% RH (no dew condensation allowed)					
Pressure connection port	G3/8 * 2					
Terminal box	Material : Aluminum die casting					
Wire outlet	G1/2	Applicable outer cable diameter : φ 6.5 to 8.0				
Structure	IP67					
Insulation resistance	100M Ω or more / 500VDC					
Withstand voltage	500VAC, 1 minute					
Vibration resistance	98.1m / s ² , 2 hours (X, Y, and Z directions)					
Weight	Approx 300g					

* 1. We also manufacture high-accuracy pressure sensors (accuracy: ± 0.25% F.S. or less).

* 2. Conversion joints (models: G3R3 and G3R2) and damper joints (model: G3R3-DSM5) are available. (See page 53 of the catalog.)

Dimensions (Units : mm)

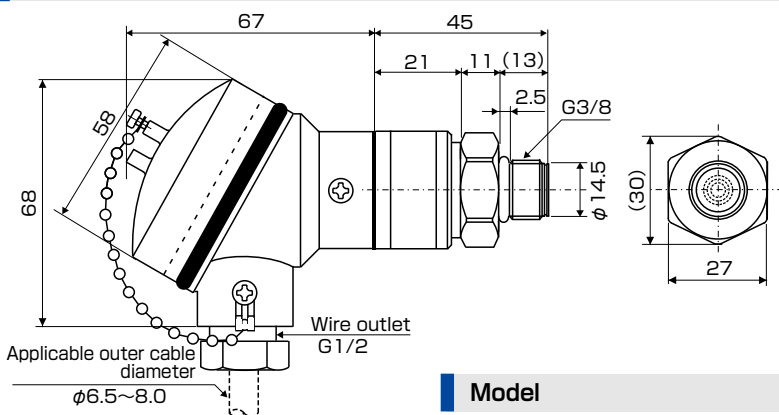

Internal terminal block / wires

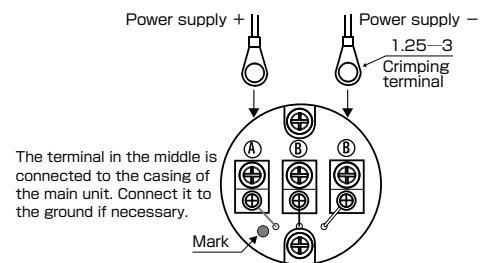

Model

MSIR - 005MP - V

- | | | | | |
|-------------|---------------------------|----------------|------------------|------------------|
| Type | Output mode | Pressure range | Unit of pressure | O-ring |
| I : Current | Special | KP : kPa | MP : MPa | V : Fluororubber |
| | R : Exposed type | | | N : NBR |
| | K : Protection cover type | | | X : Other |